

PIRADRILL USA

SCOTT MCNEILL
112 FM 153
SMITHVILLE, TX 78957
512-237-4140
SCOTT@SPIRADRILL.NET
WWW.SPIRADRILL.NET





MHD SPECIFICATIONS

The MHD is a completely hydraulic unit designed to provide more drilling capacity than comparably sized rigs. The easy to use controls and simplified design make the MHD more operator and mechanic friendly. This unit can be mounted on a 3 axle truck or crawler undercarriage. Made to drill up to 90 feet, the MHD combines the power, versatility, and efficiency needed to give you confidence on any job.

TECHNICAL SPECIFICATIONS

Maximum Pile Depth	100 feet	30.48 m
Maximum Pile Diameter	96 inches	2.44 m
Maximum Torque	43,000 ft./lbs.	58.29 kNm
Maximum rpm (low)	22 rpm	18 rpm
Maximum rpm (mid)	56 rpm	45 rpm
Spin off Speed	140 rpm	140 rpm
Main Winch	12,000 lbs.	53.33 kN
Service Winch	8,000 lbs.	31 kN
Transport weight*	43,000 lbs.	21.5 tons
Fuel Tank	50 gallons	199 liters
Crowd	24,000 lbs.	106 kN
Engine-John Deere 4045 ⁺	173 hp	

* may vary depending on configuration and undercarriage

⁺ may vary depending on configuration and undercarriage

OPTIONAL EQUIPMENT

Digital Depth and Swing Position Readout

Cold Weather Package

80' Drilling Depth option	(3 Bar, 5" x 7" x 8" square)
80' Drilling Depth option	(3 Bar, 4 1/2" x 7 1/4" x 9 1/2" round)
90' Drilling Depth option	(3 Bar, 4 1/2" x 7 1/4" x 9 1/2" round)
100' Drilling Depth option	(4 Bar, 3 1/2" x 5" x 7" x 9" square)

MHD Standard Model
Truck-Mounted
11ft-3in SWING

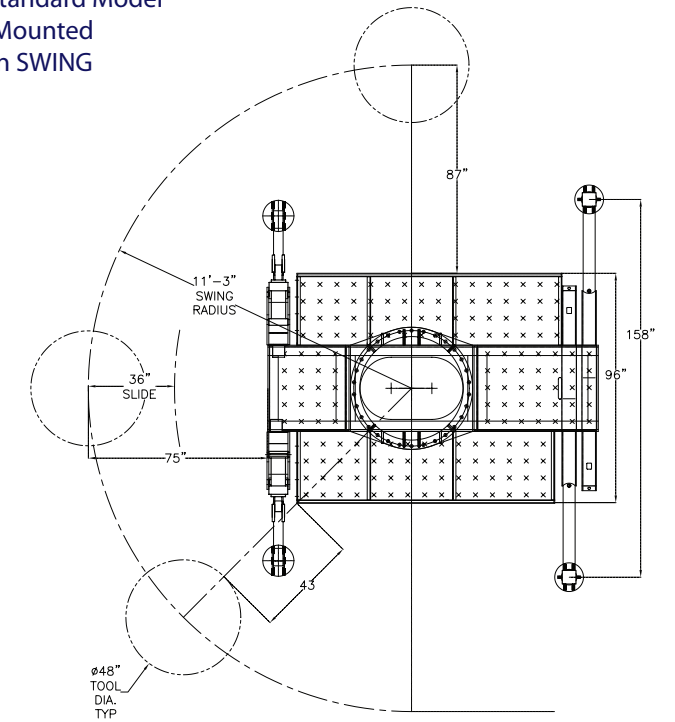

MHD-80

